

1500W Electric 2-in-1 Wall Mount Patio Heater Owner's Manual

SPH22002

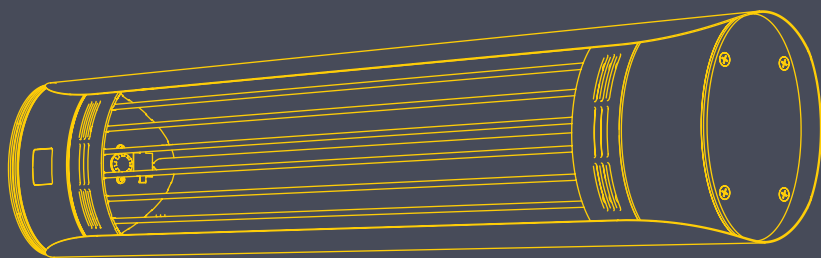

EAST OAK

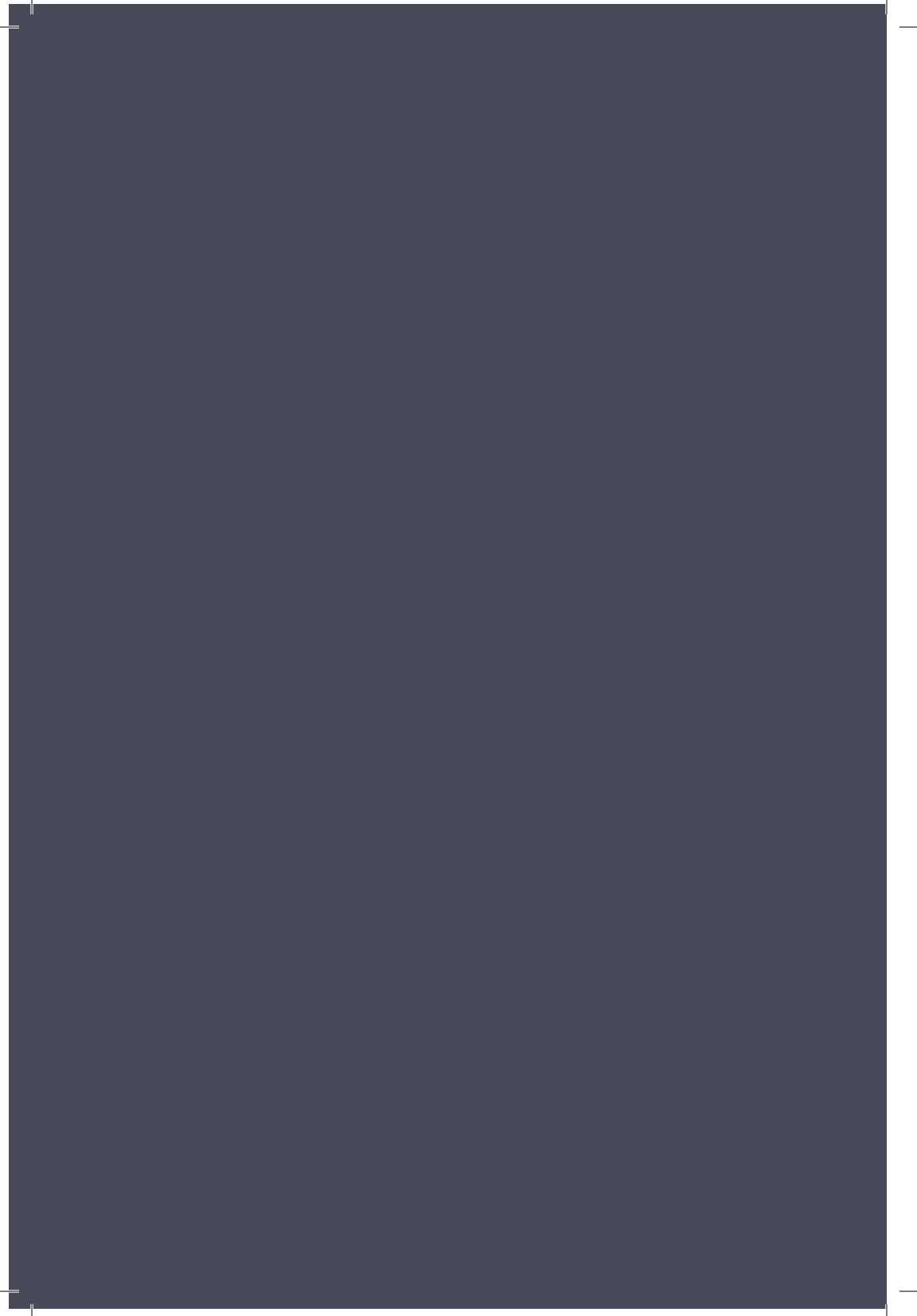

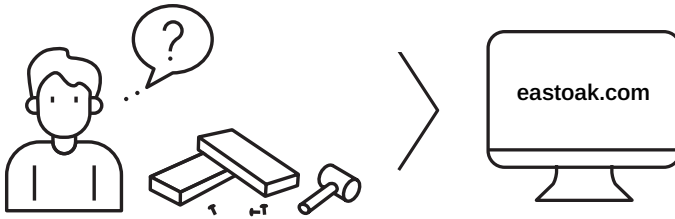

**Question? Comments?
Reach out to us to get expert support!**

✉ support@eastoak.com
🌐 eastoak.com
☎ 1-833-EAST-OAK (USA)
(1-833-327-8625)

Follow **eastoakliving** on



Claim 3-year warranty
at eastoak.com/warranty

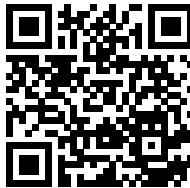

IMPORTANT CAUTION

Please verify all parts and components present and check for any damaged pieces before assembly. If you have any damaged or missing parts, please contact customer service at support@eastoak.com.

- Some parts may contain sharp edges and may cause injury or property damage. We recommend you wear protective gloves during assembly.
- If you are using power tools, please set the speed to the lowest setting possible to ensure there will be no damage to the parts.



IMPORTANT INFORMATION

DANGER

- To avoid any overheating, do not cover this product when it is in use.
- **This appliance shall be used by adults only.** Any child under the age of 8 years old or persons with reduced physical, sensory, or mental capacity may use this product if given proper supervision and instruction concerning the best practices and safety measures of the appliance. Children should not play with or clean this product.

CAUTION

- This product is **extremely hot when in use** and may cause burns, injury, or death. Children and vulnerable people should remain at least 3 feet away from this product.
- This heater cannot control room temperatures. **Do not use this heater in small rooms with children or pets.**
- This heater must not be placed immediately below a socket outlet.
- Do not place this heater close to any combustible items, such as curtains, cloth, gas, or any flammable liquids.

-
- If the cord or plug is damaged, please contact support@eastoak.com to repair and/or replace the part. Do not attempt to operate this heater prior to replacement.
 - Children under 3 years old should stay away from this product when in use unless closely supervised.
 - Children ages 3 to 8 years old shall not operate this appliance, plug or unplug it into the outlet, clean, or perform any maintenance on this product.



SAY HELLO TO THE FUTURE

Our Infrared 2-in-1 Electric Wall Mount Heater offers maximum heat with 90% less light, creating an ambient and pleasurable outdoor experience for all. Its ultra-low glare technology promises instant comfort in a matter of seconds. It can be adjusted to the height you want with the adjustable stand in the package, and the gears can be adjusted by remote control. It can use in open bars, courtyards, plazas, and stations.

Welcome warmth and the perfect amount of heat into your life now with East Oak's Infrared Electric Heater.

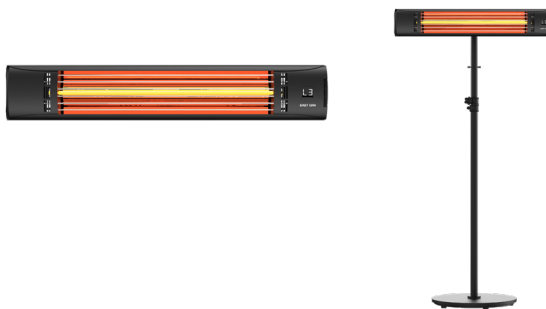

SAFETY GUIDE

When using any electrical appliance, including this infrared heater, basic safety precautions must be followed to reduce the risk of fire, shock, or injury. Please read all instructions before using this appliance:

- This heater becomes extremely hot when in use. To minimize risk of burns or injury, do not touch any part of the heater when in use. Allow enough time for product to cool down completely before handling. If applicable, use handles when transporting this product. Keep all combustible items, such as furniture, pillows, bedding, or paper, at least 3 feet away from all sides of the heater.
- Be extremely cautious of surroundings when heater is in use. No children or pets should be close to the product when it is on.
- Ensure heater is unplugged after each use.
- Do not operate this heater if it malfunctions, has been dropped, or any cords or plugs are damaged. Discard heater or send the product to an authorized service facility for inspection and/or repair.
- Do not run the cord under any carpeting, rugs, furniture, or appliances. Ensure the cord is neatly placed away from areas that are high-traffic and may be tripped over.
- Connect to properly grounded outlets only.
- To disconnect the heater, turn the switch to the "OFF" position. Then, remove the plug from the outlet. Allow the product to cool down completely.
- Do not insert any foreign objects into the ventilation system. This may result in a fire, shock, or damage to the heater.
- For fire prevention, do not block any air intakes or exhausts with any items, including newspapers, cloths, or curtains. Do not use this appliance on top of soft surfaces, such as a bed or clothes.
- Do not place any open flame sources on this appliance, such as a lit candle.
- Do not place this appliance near any combustible materials, such as gas, paint, or flammable liquids.
- Only use this heater as described in the manual. Any other use is not recommended by the manufacturer. Be aware that misuse may result in fire, shock, or injury.
- Only plug the heater directly into a grounded outlet with protective connection. Do not use this appliance with an extension cord or power strip.
- Always check the voltage on the name plate of the appliance with the outlet you will be inserting it into.
- The appliance is not located immediately below a wall socket-outlet.

-
- All parts of this heater may become extremely hot when in use. Do not touch the appliance and ensure there is no combustible material around the product. Misuse may result in fire, shock, damage, or injury.
 - In case of an emergency, such as shock or fire, turn off the heater and unplug the appliance immediately. Do not try to repair the product by yourself. Please contact the manufacturer or a qualified electrician.
 - Unplug the appliance and wait until the heater has completely cooled down prior to cleaning or transporting.
 - The appliance must only be mounted by an authorized specialist. Please be aware of any relevant regulations from local electric companies or regional construction organizations.

STORAGE

Do not move, reroute, or wrap cord when heater is in use.

CARE AND MAINTENANCE

- This appliance is designed with a protective aluminum exterior for added durability and low maintenance use. No serviceable parts are included.
- Prior to cleaning your product, unplug the device and wait for it to completely cool down.
- Wipe your product with only a clean, lint-free cloth or a soft bristle brush.
- Do not clean your product with any abrasive cleaners, rough brushes, or chemical products.
- If needed, you may use alcohol to clean this product.
- For your safety, do not immerse the cord, plug, or any part of the product in water or any other liquid.
- If a replacement is needed, please contact the manufacturer or a qualified electrician.
- If a replacement is needed, please contact customer service at support@eastoak.com.





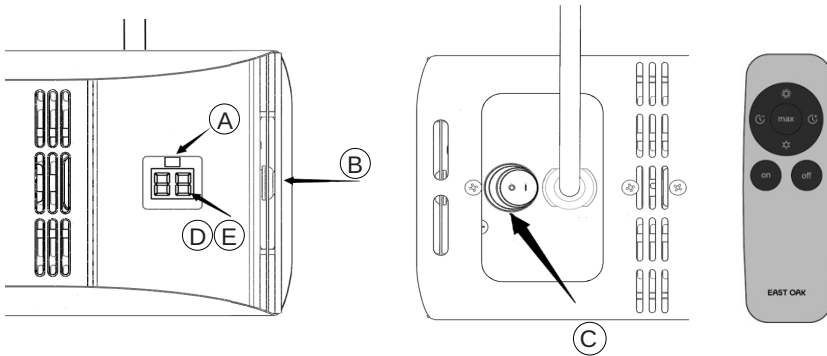

SAVE THESE INSTRUCTIONS

Specifications	
Specification	SPH22002
Voltage (V)	120V 60Hz
Power consumption (W)	1500W
IP code	IP65

FUNCTION INSTRUCTION



Remark	Graphic	Name	Function
A		Through window	Infrared receiving transparent window
B		Manual button	Switch on / off and adjust the power
C		Switch	Turn on the power or Turn off the power
D		LED - LO	1: Display the level setting of the heating (L1,L2,L3). 2: Display timing time (01-24H).
E		LED - FL	FL (Anti-dumping) Mode: During the use, when the dumping angle of the product greater than 10°, it will activate the Anti-dumping Mode. The LED will keeps flicking. How to cancel the FL Mode: Option1: Use the remote control "OFF" to reset the LED, until the screen shows "- -". Option2: Use the manual button "B" to reset the LED, until the screen shows "- -". *NOTE: The power is not able to adjust under the FL mode. How to reset the heater: Step1: Place the heater back in the initial level. Step2: Restart the power.

Button	Graphic	Feature
Up Arrow		Up one heating level
Max		The heater goes directly to the highest heating level
Down Arrow		Down one heating level
Timing Key -		1-24h setting, press once to reduce 1 hour, display the remaining time on the screen, and press for a long time to enter the setting mode.
Timing Key +		1-24h setting, press once to increase 1 hour, display the remaining time on the screen, and press for a long time to enter the setting mode.
On		To switch the heater on: Press ON. The patio heater has a soft start function of 50% power, 4 seconds after the heater has been turned on, it will automatically switch to the last heating level used. In case of the first-time use, after 4 seconds the heater will automatically switch to 100% power.
Off		To switch the heater off: Press OFF. The heater will switch to standby mode (the receiver indicator will light up).

REMOTE CONTROL GUIDE

1. Remote control distance works up to 3-4 m.
2. For optimal usage, align the remote to the receiver as illustrated here.

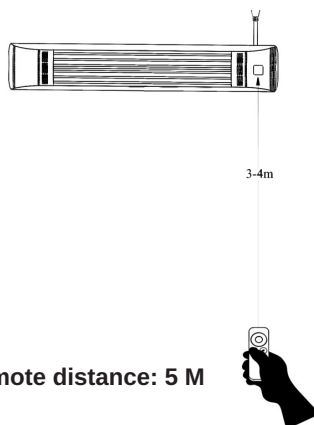

NOTICE

- The remote control works with 2 AAA 1.5V batteries (sold separately). If the appliance will not be in use, remove the batteries from the remote to minimize any risk of damage.
- Ensure only the approved battery sizes is used for the remote. Misuse may result in damage to the remote or unit's function.
- Contact a service technician for additional assistance if needed.
- Remote may not work if there is a physical blockage interfering between the appliance and remote.
- Replace all batteries as needed to ensure proper function of appliance and remote.

1

OPERATION INSTRUCTION

Inspect all components, including the main unit, supply cord, and plugs, for any signs of damage. Take off all screws.

If any parts or hardware pieces are missing or damaged, please contact customer service at support@eastoak.com. In your email, include your shipping address and product information. We will send you replacement parts for free.

Take out the L-shaped bracket from the plastic bag and mount the brackets on the wall with the help of anchor dowels.

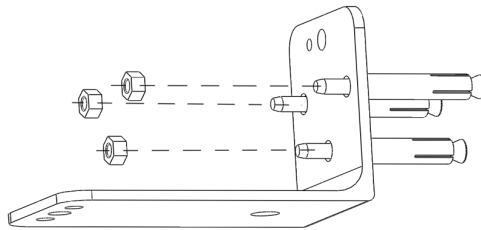

2

Connect the heater to the L-shaped bracket.

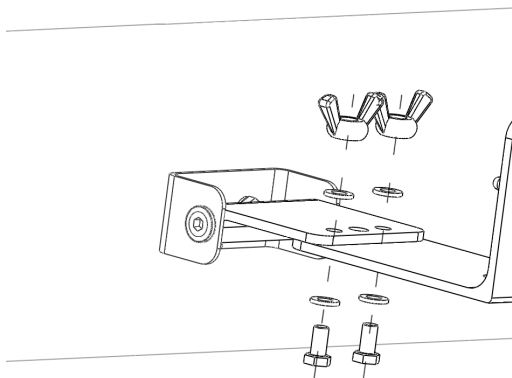

3

Adjust the required angle of the heater, and tighten the T-nut.

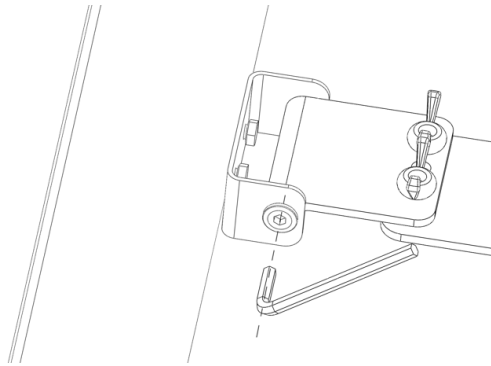

4

- Don't move or cover the heater while it is working.
- Warn that the heater must be installed appropriately before it is used.
- Connect the plug to the socket.
- Turn on the switch and connect the power to check if the heater can work well.
- Plug in the power source and operate the remote control. Then observe whether the appliance works trouble-free during the first 10-15 minutes.
- If you do not use it, please remove the battery socket.
- This heater includes an **Overheat Protection System** that shuts the unit off when parts of the heater overheat. If this occurs, turn the heater off, unplug it, and inspect and remove any objects on or adjacent to the heater that may cause high temperatures. Wait five to ten minutes for the unit to cool down. Then plug it back in, and resume the regular operation.

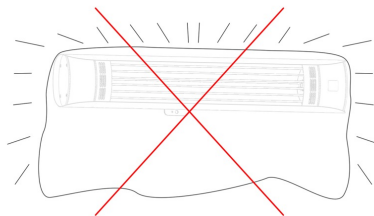

GROUNDING INSTRUCTIONS

This heater is compatible with 120-volt sockets. The plug (A) is shown Figure 60.1. An adapter (C) is available to adapt three-blade plugs to two-slot sockets. The green grounding extension must be connected to a permanent ground, such as an outlet box. The adapter should not be used if a three-slot socket is available.

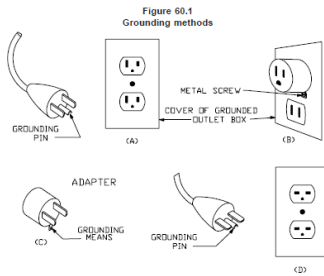

SERVICE

- For your safety, all repairs must be done by an authorized and trained electrician only.
- Please contact the manufacturer or an electrician for your choice.
- Unauthorized repairs may lead to property damage, injury, or death.
- Unauthorized repairs may lead to property damage, injury, or death.
- Our warranty does not cover any damage resulting from unauthorized repairs, accidents, misuse, or maintenance abuse.
- We are committed to continuous product development and we reserve the right to change the product and documentation specifications without notice.
- For any services, please contact customer service at support@eastoak.com.

WARRANTY

GUARANTEED 3-YEAR WARRANTY

Thank you for choosing East Oak. This product is covered by our company warranty for up to 3 years from its original purchase date.

CLAIM WARRANTY

To claim your product's warranty, register your new product on our website at www.eastoak.com/warranty.

The first part of the document discusses the importance of maintaining accurate records in a laboratory setting. It emphasizes the need for clear labeling and consistent data entry to ensure the reliability of experimental results. The text also touches upon the ethical considerations of data handling and the responsibilities of researchers in this regard.

In the second section, the author details the methodology used for the experiments. This includes a description of the equipment used, the procedures followed, and the variables being measured. The goal is to provide a clear and replicable account of the experimental process.

The results of the experiments are presented in the third section. The data is organized into tables and graphs to facilitate analysis. The author discusses the trends observed in the data and compares them with theoretical expectations. It is noted that the experimental results generally align with the theoretical predictions, though some deviations are observed.

Finally, the document concludes with a discussion of the implications of the findings. The author suggests that the results have significant implications for the field of study and offers some recommendations for further research. The overall tone of the document is professional and objective, focusing on the scientific aspects of the work.

EAST OAK

✉ support@eastoak.com

🌐 eastoak.com

☎ 1-833-EAST-OAK (USA)